

## HOW YOUR TRAILER BRAKES OPERATE

The trailer brake is basically the same as your automobile brake. The major difference is the automobile uses hydraulic pressure to expand the brake shoes while your trailer uses an electric circuit.

When the electrical circuit is complete, high capacity electromagnets are energized and attracted to the armature surface on the brake drum. Due to the rotation of the drum, the electromagnets move the magnet lever arm in the same direction. This movement causes the actuating block to push the primary brake shoe against the drum. The force of the primary shoe in turn pushes the secondary brake shoe in contact with the drum.

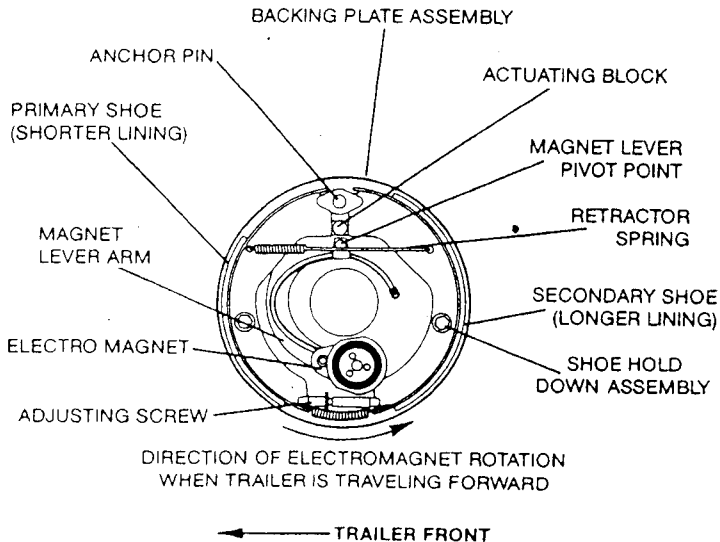

## ELECTRIC BRAKE CIRCUIT

